



AQ2L

AlfaQ™ AHRI-certified plate heat exchanger

Applications

General heating and cooling duties.

Standard design

The plate heat exchanger consists of a pack of corrugated metal plates with portholes for the passage of the two fluids between which heat transfer will take place.

The plate pack is assembled between a fix frame plate and a movable pressure plate and compressed by tightening bolts. The plates are fitted with a gasket which seals the interplate channel and directs the fluids into alternate channels. The number of plates is determined by the flow rate, physical properties of the fluids, pressure drop and temperature program. The plate corrugations promote fluid turbulence and support the plates against differential pressure.

The plate and the pressure plate are suspended from an upper carrying bar and located by a lower guiding bar, both of which are fixed to a support column.

Connections are located in the frame plate or, if either or both fluids make more than a single pass within the unit, in the frame and pressure plates.

Typical capacities

Liquid flow rate

Up to 20 kg/s (317 gpm), depending on media, permitted pressure drop and temperature program.

Plate types

AQ2L

Frame types

FM, FG and FD

Working principle

Channels are formed between the plates and the corner ports are arranged so that the two media flow through alternate channels. The heat is transferred through the plate between the channels, and complete counter-current flow is created for highest possible efficiency. The corrugation of the plates provides the passage between the plates, supports each plate against the adjacent one and enhances the turbulence, resulting in efficient heat transfer.



AQ2L-FG

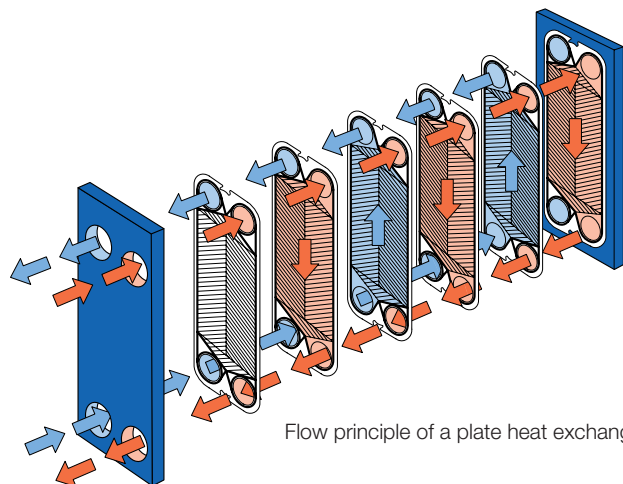

Flow principle of a plate heat exchanger

STANDARD MATERIALS

Frame plate

Mild steel, painted

Nozzles

Carbon steel

Metal lined: Stainless steel, Titanium

Pipe: Stainless steel, Titanium

Rubber lined: Nitrile, EPDM

Plates

Stainless steel Alloy 316 / Alloy 304 Titanium

Gaskets

Nitrile, EPDM

TECHNICAL DATA

Pressure vessel codes, PED, ASME, pvcALS™

Mechanical design pressure (g) / temperature

FM pvcALS™	1.0 MPa / 180°C
FM PED	1.0 MPa / 180°C
FG pvcALS™	1.6 MPa / 180°C
FG PED	1.6 MPa / 180°C
FG ASME	150 psig / 482°F
FD pvcALS™	2.5 MPa / 180°C
FD PED	2.5 MPa / 180°C
FD ASME	300 psig / 482°F

CONNECTIONS

Pipe connections (not for frame type FD)

Straight threaded Size 50 mm ISO G2", NPT 2"

Flange connections

FM pvcALS™	Size 50 / 65 mm	DIN/GB/GOST PN16, ASME Cl.150 JIS 10K
FM PED	Size 50 / 65 mm	DIN PN16, ASME Cl. 150
FG pvcALS™	Size 50 / 65 mm	DIN/GB/GOST PN16, ASME Cl. 150 JIS 10K/16K
FG PED	Size 50 / 65 mm	DIN PN16, ASME Cl. 150
FG ASME	Size 50 - 65	ASME Cl.150
FD pvcALS™	Size 50 / 65 mm	DIN/GB/GOST PN40, ASME Cl.300 JIS 20K
FD PED	Size 50 / 65 mm	DIN PN40, ASME Cl. 300
FD ASME	Size 50 / 65 mm	ASME Cl. 300

The number of tightening bolts may vary depending on pressure rating.

Dimensions

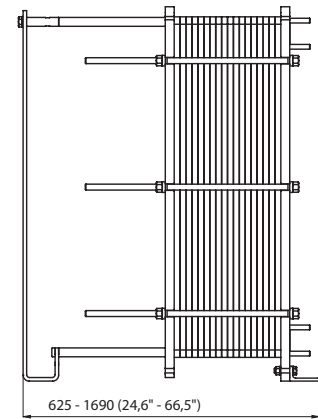
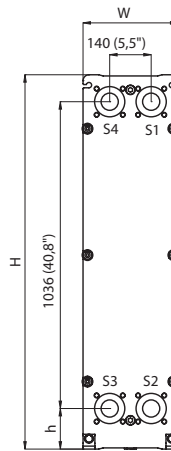

Measurements mm (inch)

Type	H	W	h
AQ2L-FM / PED / pvcALS™ 1264 (49.8")	1264 (49.8")	320 (12.6")	137 (5.4")
AQ2L-FG / PED / pvcALS™ 1264 (49.8")	1264 (49.8")	320 (12.6")	137 (5.4")
AQ2L-FG / ASME	1299 (51.1")	320 (12.6")	142 (5.6")
AQ2L-FD / PED / pvcALS™ 1264 (49.8")	1264 (49.8")	330 (13.0")	137 (5.4")
AQ2L-FD / ASME	1308 (51.5")	330 (13.0")	142 (5.6")

Maximum heat transfer surface

102.0 m² (1097 sq.ft)

Particulars required for quotation

- Flow rates or heat load
- Temperature program
- Desired working pressure
- Maximum permitted pressure drop



How to contact Alfa Laval

Up-to-date Alfa Laval contact details for all countries are always available on our website at www.alfalaval.com